

Model 1230ES

MAST BOOM LIFTS



MORE ECONOMIC

- Electric drive for zero emissions and near-silent running indoors.

MORE PRODUCTIVE

- Boost efficiency with proportional controls and direct electric drive.

MORE ACCESS

- Compact dimensions mean easier access to and within confined spaces.

SMART DESIGN

- Enjoy industry leading upcycles so you can work longer with higher productivity.



Standard Features

- Self-closing saloon style gates
- Removable platform console box
- Lanyard attach points
- Full proportional drive joystick control with integral thumb steer switch
- Proportional lift/lower speed control
- Joystick enable for lift and drive
- Automatic positive traction
- Programmable "Personality" settings
- On-board self-diagnostic testing
- Swing-out battery/electrical compartment doors
- 20 amp automatic battery charger
- Dual motor direct electric front wheel drive & steer
- Dual wheel automatic brakes
- Emergency brake release
- Pothole protection system
- AC cable to platform
- Battery condition indicator
- Hour meter
- 3 section steel mast
- Manual descent
- Horn
- Slope alarm and light
- Tie down lugs

Standard Specifications

- Tyres (Non-Marking Solid) 323 x 100
- Drive 24V Electric 6 kW
- Batteries - deep cycle 4 x 6V 220 A/hr
- Charger (120/240V – 50/60Hz) 20 Amp Automatic
- Hydraulic System 4.0 L

Accessories & Options

- 220 A/hr AGM Batteries
- All motion alarm
- Descent alarm
- Alarm package ¹
- Amber strobe light
- Euro Plug & Socket
- Synthetic Biodegradable Hydraulic Oil
- Special paint colour

¹ Includes all-motion alarm and amber strobe light.

Model 1230ES

MAST BOOM LIFTS

Performance

• Working Height	5.66 m
A. Platform Height – Elevated	3.66 m
B. Platform Entry Height	0.52 m
C. Platform Rail Height	1.10 m
D. Stowed Height	1.65 m
E. Platform Size (W x L)	0.69 m x 1.26 m
F. Overall Length	1.36 m
G. Overall Width	0.76 m
• Wheelbase	1.04 m
• Ground Clearance (Stowed)	6.5 cm
• Platform Capacity ¹	
• Lift / Lower Time	12 / 12 sec.
• Weight ²	790 kg
• Maximum Ground Bearing Pressure	8.65 kg/cm ²
• Drive Speed Lowered	4.8 km/h
• Gradeability	25%
• Turning Radius – Inside	11 cm
• Turning Radius – Outside	1.46 m

¹ Capacity -1 person + tools and equipment up to maximum 230kg.

² Certain options or country standards may increase weight and/or dimensions.



Reach Diagram

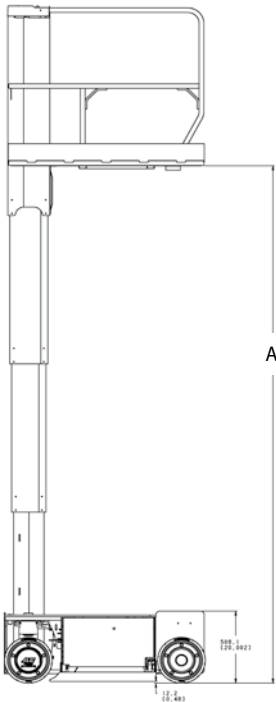

Dimensions

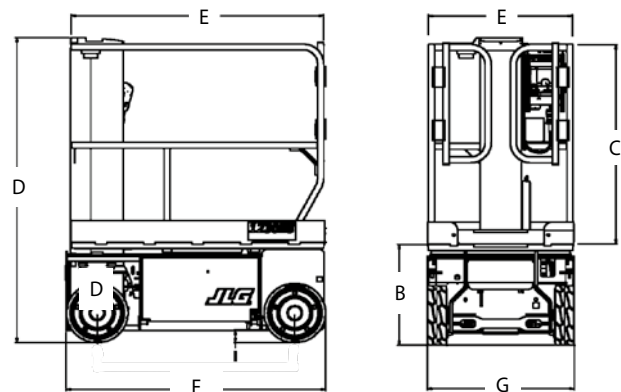

IMPORTANT

JLG is continually researching and developing products and reserves the right to make modifications without prior notice. All data in this document is indicative. Certain options or country standards will increase weight. Specifications may change to meet country standards or with the addition of optional equipment.

Due to continuous product improvements, JLG Industries reserves the right to make specification and/or equipment changes without prior notification.



JLG EMEA BV

Polaris Avenue 63
2132 JH Hoofddorp
The Netherlands
Phone: +31 (0)23 565 5665
www.jlg.com

An Oshkosh Corporation Company